

Technical features

Power supply

Three-phase voltage from 220V to 690V, 50Hz or 60Hz; suitable for use with a PWM inverter from 20Hz to the base frequency with constant torque load profile.

Polarity

2 and 4 poles.

Conformity with European Directives

Low Voltage 2006/95/EC,
ATEX 94/9/EC.

Reference Regulations

IEC/EN 60079-0, IEC/EN 60079-7, IEC/EN 61241-0, IEC/EN 61241-1, EN 60034-1,

Controls

The components that affect protection are 100% accurately controlled and recorded.

Functioning

Continual service (S1) at maximum declared centrifugal force and electric power.

Centrifugal force

Range extended up to 2615 Kgf. (25.7 KN), with centrifugal force adjustable from 0 to 100%.

Mechanical protection

IP 66 according to IEC 529, EN 60529; mechanical protection is ensured in the mounting phase of the vibrator onto the vibrating machine, by introducing the special seal into the seat on the coupling flange.

Protection against thermal protection

IK 08 according to IEC 68, EN 50102.

Insulation class

Class F (155°C).

Tropicalization

Standard on all vibrators, with vacuum encapsulation up to size 30, with "drop by drop" trickle system for larger sizes.

Ambient temperature

From -10°C to +40°C, on request it is possible to have vibrators for max. ambient temperatures of +55°C. On request special greases for temperatures less than -10°C.

Vibrator thermal protection

On demand with PTC rated thermistor heat detectors 130°C (DIN 44081-44082). Also on request thermistors with different temperatures and anti-condensation heaters.

Fixing of the vibrator

In all positions and therefore without restriction.

Lubrication

All vibrators are lubricated in the factory and do not require further lubrication if used in normal operating conditions. In heavy duty operating conditions periodical re-lubrication may be applied to frame sizes 40-50-70.

Electrical connection box

The size guarantees passage of tools used for fixing the vibrator to the vibrating machine. The electrical connection must be carried out using the relative connectors inserted inside the connection box. Special shaped terminals allow to fix the power supply cable, protecting it from loosening.

Electric motor

Three-phase asynchronous type. Designed for maximum starting torques and torque curves adapt for the specific requirements of vibrating machines. Insulated windings using vacuum encapsulating up to size 30; using the "drop by drop" trickle system with class H resin for sizes 40-50-70. The rotor is die cast aluminium.

Casing

In high-tensile aluminium alloy up to size 50, in spheroidal cast iron for size 70. An external earthing screw is located on the casing as prescribed by Regulation IEC/EN 60079-0

Bearing flange

Constructed in cast iron (ductile or grey) or in aluminium with steel bearing seat. The geometry of the flange transmits the load to the casing uniformly.

Bearings

The lower and upper bearings have been studied to support the relative load and therefore they have a particular geometry, especially designed and made for Italtvibras.

Motor shaft

In treated steel alloy (Isothermic hardening) resistant to stress.

Eccentric weights

Allow greater adjustment of the centrifugal force, with phase shift of the lower weight assembly with respect to the upper group. This adjustment is eased by a graduated scale, which expresses the centrifugal force as a percentage of the maximum centrifugal force.

Weight covers

In aluminium alloy, mounted only on the lower side. The flange side does not have weight cover. Size 40 is supplied without weights covers on both sides.

Painting

Electrostatic surface treatment based on polymerised epoxy polyester powder in oven at 200°C. Tested in salt spray for 500 hours.

Stainless steel protection

On request, corrosion high grade protection (stainless steel micro suspensions in a polyurethanic paint) is available.

2 poles - 3000/3600 rpm

	Description			Mechanical specifications						Electrical specifications									
	Code	Type	SIZE	Centrifugal force (A/B)*				Weight		Temp. class (G)	Temp. class (D)	Max input power		Power rating		Max. current		t _E (s)	I _A /I _N
				50 Hz	60 Hz	50 Hz	60 Hz	50 Hz	60 Hz			kg	kg	W	W	W	W		
three-phase	6E0369	MTF 3/200E-S02 ○	01	106/75	109/109	1.04/0.74	1.07/1.07	7.50	7.30	T3	120°C	180	180	120	120	0.33	0.33	30	2.68
	6E0370	MTF 3/300E-S02	10	151/153	148/148	1.48/1.01	1.45/1.45	11.2	10.9	T3 T4	120°C	260 230	270 230	210 172	210 172	0.57 0.48	0.50 0.41	18 12	3.50 4.20
	6E0378	MTF 3/500E-S02	20	251/163	235/235	2.46/1.60	2.30/2.30	15.0	14.1	T3 T4	120°C	500 350	500 360	300 210	300 210	0.76 0.57	0.67 0.50	12 8	4.20 5.60
	6E0456	MTF 3/650E-S02	20	393/251	377/235	3.85/2.46	3.70/2.30	15.2	14.3	T3 T4	120°C	500 350	300 360	300 210	300 210	0.76 0.57	0.67 0.50	12 8	4.20 5.60
	6E0380	MTF 3/800E-S02	30	393/262	377/377	3.85/2.57	3.70/3.70	17.0	16.5	T3 T4	120°C	550 390	570 400	405 290	405 290	0.95 0.72	0.83 0.64	12 8	4.20 5.52
	6E0285	MTF 3/1100E-S90 Δ	40	590/590	566/566	5.79/5.79	5.55/5.55	26.0	25.0	T4	120°C	830	910	660	660	1.43	1.25	6	7.30

* Listed as A/B: total centrifugal force is the sum of centrifugal force of top weights (A) and centrifugal force of bottom weights (B).

○ Available only in versions 127/220V 50Hz three-phase, 200/346V 50Hz three-phase and 210/363V 60Hz three-phase.

Δ Supplied without weight covers on both sides. t_E (s) = set time t_E from IEC/EN 60079-7. I_A/I_N = ratio between start-up current and maximum current.

Weight adjustment

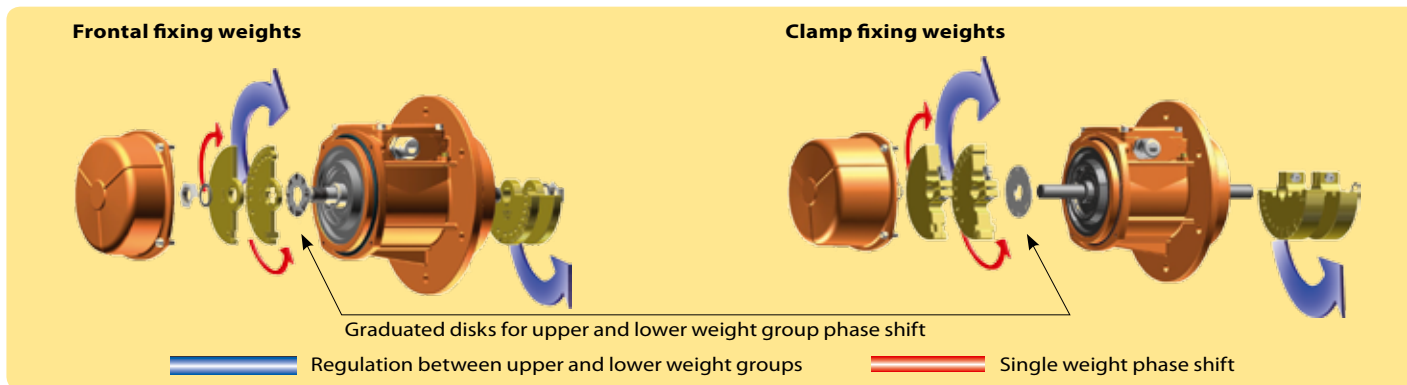

2 poles - 3000/3600 rpm

three-phase	Type	Dimensional specifications (mm)															
		Fig.	A	øB	øC	Holes			E	F	G	I	L	M	øP	Cable entry thread	Seal g
	MTF 3/200E-S02 ○	G	225.5	211.5	92	188	12	4	144	21 (50Hz) 15 (60Hz)	10	58	103	23.5	-	M20x1,5	OR 4650
	MTF 3/300E-S02	G	247	215	110	187	12	4	179.5	18 (50Hz) 12 (60Hz)	13	54	127	13.5	-	M20x1,5	OR 4625
	MTF 3/500E-S02	G	279.5	245	150	205	12	6	124	24 (50Hz) 15 (60Hz)	12	65	145	90.5	162	M25x1,5	OR 4700
	MTF 3/650E-S02	G	279.5	245	150 (50Hz) 132 (60Hz)	205	12	6	124	18	12	65	145	90.5	162	M25x1,5	OR 4700
	MTF 3/800E-S02	G	301	260	150 (50Hz) 132 (60Hz)	230	15	6	182	18	15	63	170	56	150	M25x1,5	OR 4800
	MTF 3/1100E-S90 Δ	G	383	279	145	254	14	4	-	31 (50Hz) 21 (60Hz)	17.5	57.5	-	63	229	M25x1,5	-

○ Available only in versions 127/220V 50Hz three-phase, 200/346V 50Hz three-phase and 210/363V 60Hz three-phase. Δ Supplied without weight covers on both sides.

Fig. G

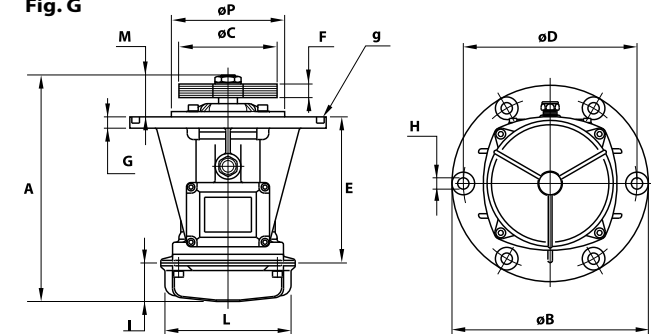

Weight adjustment

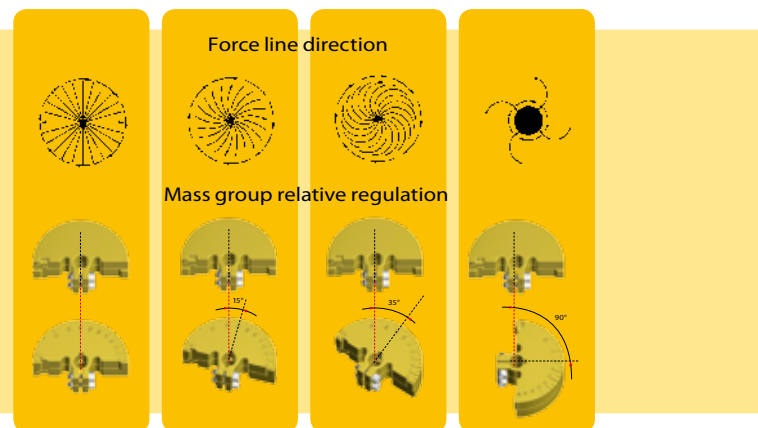

4 poles - 1500/1800 rpm

	Description			Mechanical specifications						Electrical specifications									
	Code	Type	SIZE	Centrifugal force (A/B)*				Weight		Temp. class (G)	Temp. class (D)	Max input power		Power rating		Max. current		t _E (s)	I _a /I _N
				50 Hz	60 Hz	50 Hz	60 Hz	50 Hz	60 Hz			kg	kg	W	W	50 Hz	60 Hz		
three-phase	6E1403	MTF 15/200E-S02	10	106/74	107/107	1.04/0.72	1.05/1.05	14.0	13.2	T3 T4	120°C	203 170	- 175	90 94	- 95	0.45 0.39	- 0.40	35 28	2.04 2.34
	6E1405	MTF 15/400E-S02	20	205/142	205/205	2.01/1.39	2.01/2.01	20.6	19.8	T3 T4	120°C	300 285	320 270	200 180	230 200	0.57 0.52	0.52 0.46	18 16	3.33 3.63
	6E1406	MTF 15/550E-S02	20	276/205	295/295	2.70/2.01	2.70/2.70	22.0	20.6	T3 T4	120°C	300 285	320 270	200 180	230 200	0.57 0.52	0.52 0.46	18 16	3.33 3.63
	6E1407	MTF 15/700E-S02	30	360/263	380/380	3.53/2.58	3.73/3.73	26.0	24.5	T3 T4	120°C	460 360	500 420	310 240	380 210	0.86 0.72	0.85 0.70	17 12	3.50 4.20
	6E1280	MTF 15/1100E-S90 Δ	40	522/522	491/491	5.12/5.12	4.82/4.82	36.0	31.4	T3 T4	120°C	900 630	950 700	660 460	730 505	1.38 1.05	1.32 1.00	13 8	4.00 5.36
	6E1379	MTF 15/1710E-S02-VRS	50	894/322	878/355	8.77/3.16	8.61/3.48	44.0	41.5	T3 T4	150°C	1100 630	1150 700	730 480	800 530	1.90 1.33	1.82 1.27	9 5.5	4.95 7.00
	6E1380	MTF 15/2000E-S02-VRS	50	1021/357	1017/390	10.0/3.50	9.98/3.83	48.0	45.5	T3 T4	150°C	1100 630	1150 700	730 480	800 530	1.90 1.33	1.82 1.27	9 5.5	4.95 7.00
	6E1381	MTF 15/3810E-S02-VRS	70	1908/707	1872/718	18.7/6.94	18.4/7.04	100	93	T3 T4	135°C	2200 1850	2400 1950	1780 1500	1960 1650	3.71 3.14	3.50 3.00	6 6	7.17 8.42

* Listed as A/B: total centrifugal force is the sum of centrifugal force of top weights (A) and centrifugal force of bottom weights (B).

Δ Supplied without weight covers on both sides. t_E (s) = set time t_E from IEC/EN 60079-7. I_a/I_N = ratio between start-up current and maximum current.

Weight adjustment

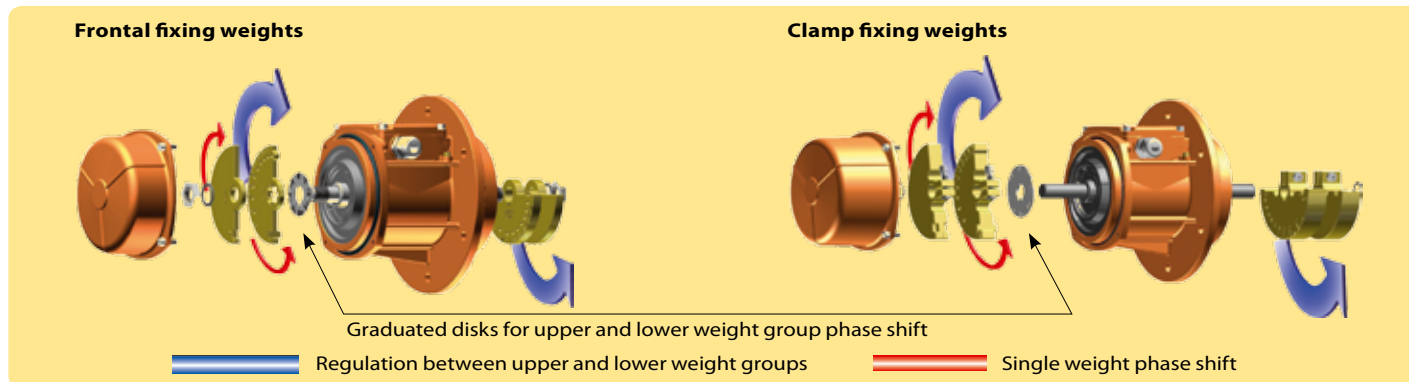

4 poles - 1500/1800 rpm

three-phase

Type	Dimensional specifications (mm)															
	Fig.	A	øB	øC	Holes			E	F	G	I	L	M	øP	Cable entry thread	Seal g
				øD	øH	N°										
MTF 15/200E-S02	G	292.5	215	114 (50Hz) 108 (60Hz)	187	12	4	179.5	48 (50Hz) 40 (60Hz)	13	77	127	36	-	M20x1,5	OR 4625
MTF 15/400E-S02	G	335.5	245	130	205	12	6	124	59 (50Hz) 42 (60Hz)	12	93	145	118.5	162	M25x1,5	OR 4700
MTF 15/550E-S02	G	376.5	245	130	205	12	6	124	79 (50Hz) 59 (60Hz)	12	114	145	138.5	162	M25x1,5	OR 4700
MTF 15/700E-S02	G	380.5	260	154	230	15	6	182	59 (50Hz) 46 (60Hz)	15	106	170	92.5	150	M25x1,5	OR 4800
MTF 15/1100E-S90 Δ	G	426	279	190	254	14	4	-	49	17.5	57.5	-	84.5	229	M25x1,5	-
MTF 15/1710E-S02-VRS	G	488	350	190	290	17	6	232	84 (50Hz) 58 (60Hz)	18	134	209	122	172	M25x1,5	-
MTF 15/2000E-S02-VRS	G	561	350	190	290	17	6	232	96 (50Hz) 66 (60Hz)	18	171	209	158	172	M25x1,5	-
MTF 15/3810E-S02-VRS	G	614	410	250 (50Hz) 244 (60Hz)	350	22	6	310	78 (50Hz) 58 (60Hz)	20	178	280	125.5	234	M25x1,5	-

Fig. G

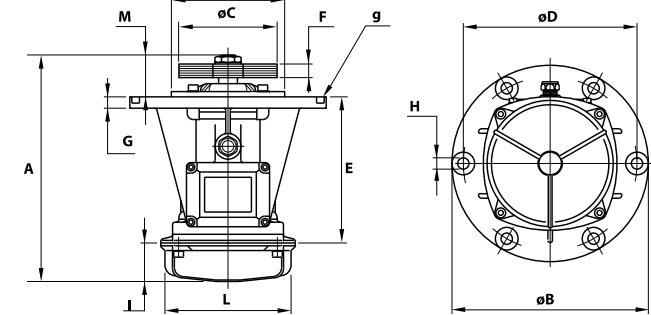

Weight adjustment

