









# Selection table

|                              | Identification                    | Characteristics   | Working temperature  | Details              | Illustration  |   |
|------------------------------|-----------------------------------|---|--|----------------------|---|---|
| Standard tensioner devices   | <b>SE</b> Standard component      | Steel parts ROSTA blue painted.<br>Rubber quality Rubmix 10.  | Housing and inner core made out of steel.                    | -40° to +80° C       | Page 4.6  |    |
|                              | <b>SE-G</b> Oil resistant         | Steel parts galvanized.<br>Rubber quality Rubmix 20.<br>Marked with yellow dot.   |  | -30° to +90° C       | Page 4.6  |    |
|                              | <b>SE-W</b> Heat resistant        | Steel parts ROSTA blue painted.<br>Rubber quality Rubmix 40.<br>Marked with red dot.<br>Tension force 40% less than SE.                           |  | +80° to +120° C max. | Page 4.6  |    |
| Additional tensioner devices | <b>SE-R</b> Reinforced lever arm  | Arm and inner core especially welded for use on combustion engines and compressors.<br>Steel parts ROSTA blue painted.<br>Marked with white ring. | Housing and inner core made out of steel, inserts Rubmix 10. | -40° to +80° C       | Page 4.6  |    |
|                              | <b>SE-I</b> Stainless steel       | For the use in food- and pharmaceutic industries.<br>Material: GX5CrNi19-10.<br>Exception: SE-I 40 made out of X5CrNi18-10.                       |  |                      | Page 4.6  |   |
|                              | <b>SE-F</b> Front mounting-device | For installations on blind-hole frames (fixation from the front only).<br>Steel parts ROSTA blue painted.<br>Hex socket screw quality 12.9.       |  |                      | Page 4.7  |  |
|                              | <b>SE-B</b> Boomerang®            | For the tensioning of very long chain and belt drives (triple compensation).<br>Steel parts ROSTA blue painted.                                   |  |                      | Page 4.7  |  |
| Accessories chain drives     | <b>Sprocket wheel set N</b>       | Allows accurate positioning of relevant chain track.<br>Ball-bearings 2Z/C3, permanently lubricated.  | -40° to +100° C  | Page 4.8             |  |   |
|                              | <b>Sprocket wheel N</b>           |   |  |                      |   |   |
|                              | <b>Chain rider set P</b>          | For double sided use.<br>Max. allowed chain speed 1.5 m/sec.<br>Material: POM-H.  | -40° to +100° C  | Page 4.9             |  |   |
| <b>Chain rider P</b>         |                                   |   |  |                      |   |   |
| Accessories belt drives      | <b>Tensioning roller R</b>        | Material: PA 6.<br>Ball-bearings 2Z/C3, permanently lubricated.   | -35° to +100° C  | Page 4.10            |  |   |

Further information to customized elements and installation examples as from page 4.12.

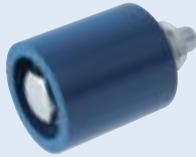

# General technology

The ROSTA tensioners should be installed on a stiff, even and clean machine part by means of the central bolt. The frictional connection on flange is usually fully sufficient for final positioning. The positioning notch on flange can be used to assure the tensioner additionally on uneven and dirty surfaces by setting a roller-pin.

## Tensioning force F

The tensioning force can be continuously adjusted. The max. pre-tensioning angle is +30° out of neutral position. Tensioning force table for types **SE / SE-G / SE-R / SE-F / SE-I** by using **hole-position "normal"** for sprocket-, rider- and roller fixation.

| Size SE | Pre-tension $\leq 10^\circ$ |        | Pre-tension $\leq 20^\circ$ |        | Pre-tension $\leq 30^\circ$ |        |
|---------|-----------------------------|--------|-----------------------------|--------|-----------------------------|--------|
|         | F [N]                       | s [mm] | F [N]                       | s [mm] | F [N]                       | s [mm] |
| 11      | 15                          | 14     | 40                          | 28     | 80                          | 40     |
| 15      | 25                          | 17     | 65                          | 34     | 135                         | 50     |
| 18      | 75                          | 17     | 180                         | 34     | 350                         | 50     |
| 27      | 150                         | 22     | 380                         | 44     | 800                         | 65     |
| 38      | 290                         | 30     | 730                         | 60     | 1500                        | 87     |
| 45      | 500                         | 39     | 1300                        | 78     | 2600                        | 112    |
| 50      | 750                         | 43     | 2150                        | 86     | 4200                        | 125    |

**SE-I 40:** same tensioning force like SE 38.

**SE-W:** 40% lower tensioning force than standard versions (Rubmix 40 inserts).

**When fixing the sprockets, riders and rollers in arm-position "hard", tensioning force will increase on about 25%.**

## Mounting instructions

For further mounting instructions please consult the pages 4.9–4.11.

### Z-configuration of sprockets or riders

If there is the need to install sprockets, riders or rollers on the outer arm-side of the tensioner, then the distance "Z" should be as little as possible to avoid a misalignment in element parallelism. Furthermore the pre-tension force should not exceed 50% of the capacity = max. pre-tension angle of ~20°.



### Use of SE-B Boomerang® tensioners

In very long chain and belt drives it was recommendable to install on the slack-side several tensioners, in order to compensate occurring elongation. The "Boomerang" with its bent double-arm equipped with two chain sprockets or a combination of grooved pulley and flat-roller (belt-drives) **offers a triple-compensation of chain and belt elongations, due to S-shape contact-arc.**

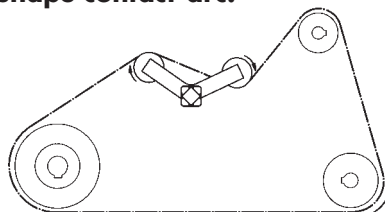

### Tensioner mounting

Tighten the flange screw slightly. Grip the housing with flat-wrench and set needful pre-tension by rotating the housing in the required direction. Tighten the central screw according the above mentioned tightening moment  $M_A$ .

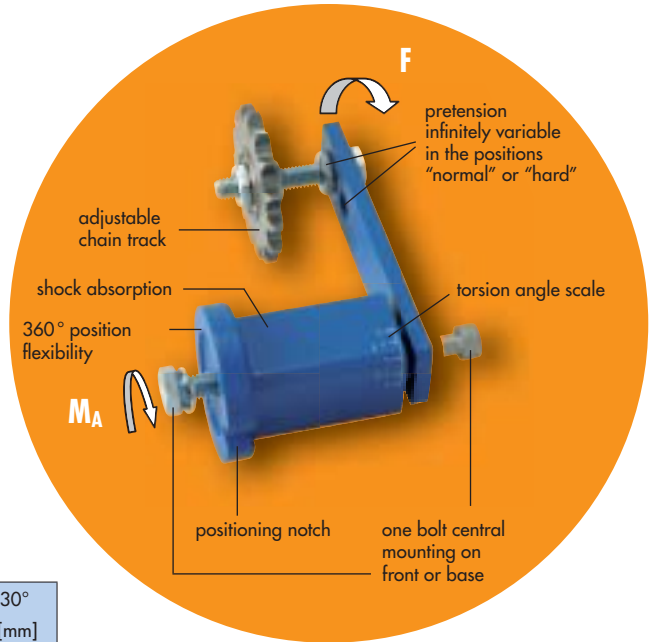
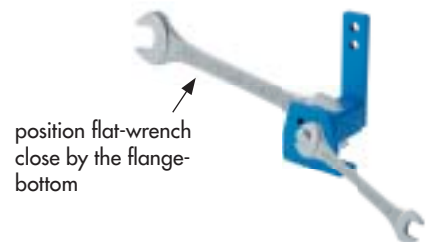

## Tightening moment $M_A$ for attachment screw

Table mentioning the tightening moment for the central screw (included in scope of delivery).

|     | Quality 8.8 | Quality 12.9 only with SE-F |
|-----|-------------|-----------------------------|
| M6  | 10 Nm       | 17 Nm                       |
| M8  | 25 Nm       | 41 Nm                       |
| M10 | 49 Nm       | 83 Nm                       |
| M12 | 86 Nm       | 145 Nm                      |
| M16 | 210 Nm      | 355 Nm                      |
| M20 | 410 Nm      | 690 Nm                      |
| M24 | 750 Nm      |                             |



## Tensioner Devices

Type SE/SE-G/SE-W

Type SE-R

Type SE-I

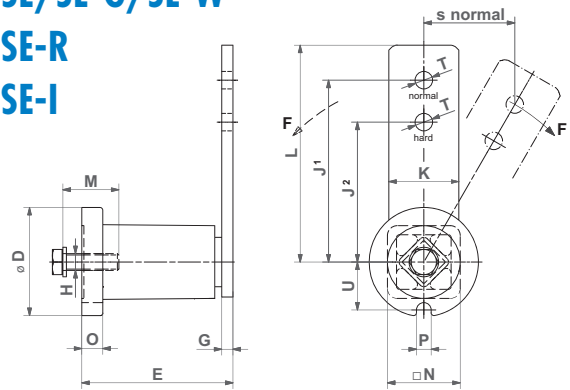

### Standard Tensioner Devices Types SE / SE-G / SE-W

| Type                               | Art. No.                                      | D   | E                                  | G  | H   | J <sup>1</sup> | J <sup>2</sup> | K  | L     | M  | N  | O    | P    | T    | U    | Weight [kg] |
|------------------------------------|---|-----|------------------------------------|----|-----|----------------|----------------|----|-------|----|----|------|------|------|------|-------------|
| <b>SE 11</b><br>SE 11-G            | <b>06 011 001</b><br>06 013 201               | 35  | 51 <sup>+1</sup> <sub>-0.5</sub>   | 5  | M6  | 80             | 60             | 20 | 90    | 20 | 22 | 6    | 8    | 8.5  | 16.5 | 0.2         |
| <b>SE 15</b><br>SE 15-G<br>SE 15-W | <b>06 011 002</b><br>06 013 202<br>06 015 002 | 45  | 64 <sup>+1</sup> <sub>-0.5</sub>   | 5  | M8  | 100            | 80             | 25 | 112.5 | 25 | 30 | 8    | 8.5  | 10.5 | 20.8 | 0.4         |
| <b>SE 18</b><br>SE 18-G<br>SE 18-W | <b>06 011 003</b><br>06 013 203<br>06 015 003 | 58  | 79 <sup>+1.5</sup> <sub>-0.5</sub> | 7  | M10 | 100            | 80             | 30 | 115   | 30 | 35 | 10.5 | 8.5  | 10.5 | 25.3 | 0.6         |
| <b>SE 27</b><br>SE 27-G<br>SE 27-W | <b>06 011 004</b><br>06 013 204<br>06 015 004 | 78  | 108 <sup>+2</sup> <sub>-0.5</sub>  | 8  | M12 | 130            | 100            | 50 | 155   | 40 | 52 | 15   | 10.5 | 12.5 | 34.3 | 1.7         |
| <b>SE 38</b><br>SE 38-G<br>SE 38-W | <b>06 011 005</b><br>06 013 205<br>06 015 005 | 95  | 140 <sup>+2</sup> <sub>-0.5</sub>  | 10 | M16 | 175            | 140            | 60 | 205   | 40 | 66 | 15   | 12.5 | 20.5 | 42.0 | 3.6         |
| <b>SE 45</b><br>SE 45-G<br>SE 45-W | <b>06 011 006</b><br>06 013 206<br>06 015 006 | 115 | 200 <sup>+3</sup> <sub>-1</sub>    | 12 | M20 | 225            | 180            | 70 | 260   | 50 | 80 | 18   | 12.5 | 20.5 | 52.0 | 6.4         |
| <b>SE 50</b><br>SE 50-G<br>SE 50-W | <b>06 011 007</b><br>06 013 207<br>06 015 007 | 130 | 210 <sup>+3</sup> <sub>-1</sub>    | 20 | M24 | 250            | 200            | 80 | 290   | 60 | 87 | 20   | 17   | 20.5 | 57.5 | 9.0         |

### SE-R Tensioning element with strengthened tensioning arm

| Type           | Art. No.   | D  | E                                  | G | H   | J <sup>1</sup> | J <sup>2</sup> | K  | L     | M  | N  | O    | P   | T    | U    | Weight [kg] |
|----------------|------------|----|------------------------------------|---|-----|----------------|----------------|----|-------|----|----|------|-----|------|------|-------------|
| <b>SE-R 15</b> | 06 011 702 | 45 | 64 <sup>+1</sup> <sub>-0.5</sub>   | 5 | M8  | 100            | 80             | 25 | 112.5 | 25 | 30 | 8    | 8.5 | 10.5 | 20.8 | 0.4         |
| <b>SE-R 18</b> | 06 011 703 | 58 | 79 <sup>+1.5</sup> <sub>-0.5</sub> | 7 | M10 | 100            | 80             | 30 | 115   | 30 | 35 | 10.5 | 8.5 | 10.5 | 25.3 | 0.6         |

### SE-I Tensioning element made out of stainless steel, INOX

| Type           | Art. No.   | D   | E                                  | G  | H   | J <sup>1</sup> | J <sup>2</sup> | K  | L     | M  | N  | O    | P    | T    | U    | Weight [kg] |
|----------------|------------|-----|------------------------------------|----|-----|----------------|----------------|----|-------|----|----|------|------|------|------|-------------|
| <b>SE-I 15</b> | 06 071 111 | 45  | 64 <sup>+1</sup> <sub>-0.5</sub>   | 5  | M8  | 100            | 80             | 25 | 112.5 | 25 | 30 | 8    | 8.5  | 10.5 | 20.8 | 0.4         |
| <b>SE-I 18</b> | 06 071 112 | 58  | 79 <sup>+1.5</sup> <sub>-0.5</sub> | 7  | M10 | 100            | 80             | 30 | 115   | 30 | 35 | 10.5 | 8.5  | 10.5 | 25.3 | 0.7         |
| <b>SE-I 27</b> | 06 071 113 | 78  | 108 <sup>+2</sup> <sub>-0.5</sub>  | 8  | M12 | 130            | 100            | 50 | 155   | 40 | 52 | 15   | 10.5 | 12.5 | 34.3 | 2.1         |
| <b>SE-I 40</b> | 06 071 104 | 100 | 140 <sup>+2</sup> <sub>-0.5</sub>  | 10 | M16 | 175            | 140            | 70 | 205   | 40 | 70 | 15   | 12   | 20.5 | 41.5 | 3.8         |

Further product and performance datas on pages 4.4–4.5.