



















Selection chart for rubber suspension standard elements with Rubmix 10

Inner square Housing	A Light metal profile, as from size 60 in steel	C Light metal profile	S Steel tube for plug-in connection	Accessories for housing Steel parts
DR Steel tube	DR-A 15 to 50  Page 1.6	DR-C 15 to 50  Page 1.6	DR-S 11 to 50  Page 1.7	Bracket BR 11 to 50  Page 1.7
DK Light metal profile	DK-A 15 to 50  Page 1.8	DK-C on request 	DK-S 11 to 50  Page 1.8	Bracket BK 11 to 50  Page 1.9
DW Light metal profile	DW-A 15 to 38  Page 1.10	DW-C 15 to 38  Page 1.10	DW-S on request 	Accessories for inner square A Steel parts WS 11 to 50  Page 1.13
DW Nodular cast iron	DW-A 45 and 50  Page 1.11	DW-C 45 and 50 on request 	DW-S on request 	
DW Steel welded construction	DW-A 60 to 100  Page 1.11			
DO Light metal profile Size 50 in nodular cast iron	DO-A 15 to 50  Page 1.12	DO-C on request 	DO-S on request 	
Housing Specification inner squares	Ideal for alternating motions over neutral element position. For sizes DR 15–45: Fixation by means of 2 to 4 persistent threaded bars (sizes DR 27–45 also available with threaded holes).	Friction locking of the core by means of one central bolt, can be positioned in full 360° angle-range. For ideal friction locking, please remove paint cover on face side. For alternating element motion of max. ±10°.	For plug-in connection with square profile*. Plug-in length min. 2 x width across flat "C". Connection is not recommendable by alternating motions – play between the plugged squares.	* The square should be made out of bright steel, tolerance h9–h11. Possibly, the edges have to be overwinded (edge-radius in element profile max. 1.5 mm).

Specification

DR-A 15 x 25

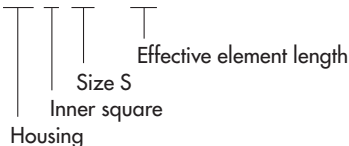

General

- Light metal profiles: extruded profiles, seawater resistant (DIN 1725).
- Blue protection paint: water-soluble paint, coating thickness 0.04–0.08 mm.
- Fixation screws: minimum strength class of 8.8
- Welding on elements: do not weld on rubber suspensions – welding heat will affect or destroy the rubber inserts – ask for customized elements
- Most of the elements can be supplied in stainless steel version – also zinc-plated versions or special paintings are available.

Further customized elements: see examples on page 1.14 to 1.19.

List of torque and loads

The values stated in the below mentioned list have been measured statically and are valid for the standard rubber quality "Rubmix 10". Intermediate values can be interpolated. By applications with combined dynamic forces and high angles of oscillation please consult our ROSTA general catalogue, chapter "Technology" or contact ROSTA.

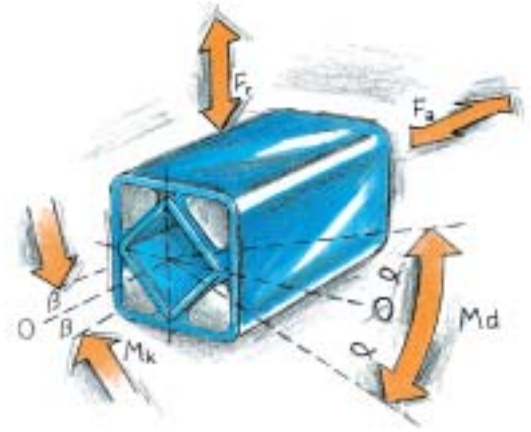

Element Nominal size x Length	Torque						Cardanic Mk [Nm] angle ±β°	Radial		Axial	
	Md [Nm] angle ±α°							Deflection ± s _r [mm]	Load F _r [N]	Deflection ± s _a [mm]	Load F _a [N]
	5°	10°	15°	20°	25°	30°					
11 x 20	0.3	0.8	1.3	2.0	2.9	4.0	0.4		200		60
	0.4	1.2	2.0	3.1	4.3	6.0	1.1	0.25	340	0.25	80
	0.7	2.0	3.4	5.1	7.2	10.0	5.6		600		150
15 x 25	0.7	1.6	2.6	4.0	5.7	8.2	0.6		200		70
	1.1	2.5	4.2	6.4	9.2	13.2	2.0	0.25	300	0.25	100
	1.6	3.8	6.3	9.6	13.8	19.8	5.5		500		160
18 x 30	1.9	4.5	7.5	11.0	15.0	20.6	1.6		400		80
	3.2	7.5	12.5	18.3	25.0	34.4	7.0	0.25	700	0.25	160
	5.1	12.0	20.0	29.3	40.0	55.0	28.0		1000		300
27 x 40	4.7	10.7	17.5	26.9	39.5	57.0	3.8		800		200
	7.0	16.0	26.3	40.3	59.3	85.5	11.5	0.5	1300	0.5	300
	11.7	26.7	43.8	67.2	98.8	142.5	48.0		2400		600
38 x 60	13.0	30.4	50.6	78.0	113.0	162.0	11.4		1500		300
	17.3	40.5	67.5	104.0	151.0	216.0	24.7	0.5	2000	0.5	500
	26.0	60.8	101.2	156.0	226.0	324.0	76.0		3000		600
45 x 80	27.6	62.4	104.0	160.0	222.0	320.0	28.0		1900		560
	34.5	78.0	130.0	200.0	278.0	400.0	54.0	0.5	3000	0.5	700
	51.8	117.0	195.0	300.0	420.0	600.0	140.0		4800		1000
50 x 120	51	133	250	395	570	780	80		2800		800
	77	197	363	570	820	1115	145	0.5	4500	0.5	950
	102	260	475	745	1070	1450	250		6300		1100
	150	385	700	1100	1590	2160	1200		8600		2200
60 x 150	75	170	300	460	700	1010	90		5400		1600
	95	220	385	610	930	1380	250	1.0	7200	1.0	2200
	140	365	630	995	1550	2240	900		9400		3200
70 x 200	140	380	650	1040	1490	2120	280		9000		2200
	190	525	910	1470	2160	3150	1200	1.0	12'000	1.0	3600
	250	765	1315	2160	3175	4750	2200		14'000		4000
80 x 200	200	500	850	1300	1900	2700	680		10'000		2500
	300	800	1300	2000	2900	4100	1500	1.0	15'000	1.0	3800
	400	1060	1800	2800	3900	5600	4600		19'000		4700
100 x 250	400	1080	1800	2800	4100	6300	1200		15'000		3200
	640	1700	2900	4500	6600	10'000	4300	1.0	28'000	1.0	5800
	800	2160	3600	5600	8200	12'000	8000		38'000		7500



Rubber Suspension Units

Type DK-A

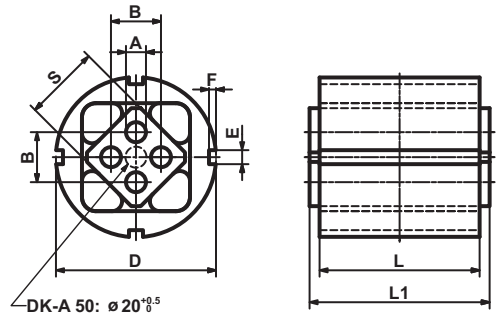

DK-A 50: $\varnothing 20^{+0.5}$

Type DK-S

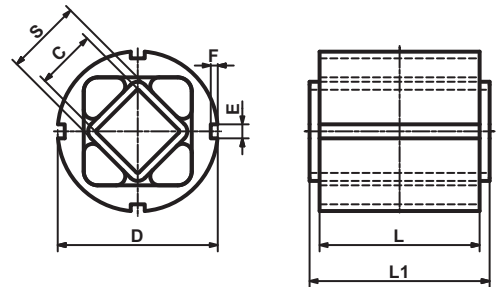

DK-A				DK-S				$\varnothing D$	E	F	$\square S$	L	L1 ± 0.2	
Art. No.	Type	$\varnothing A^{+0.5}_0$	B	Weight [kg]	Art. No.	Type	$\square C$							Weight [kg]
					01 081 001	DK-S 11x 20		0.03				20	25	
					01 081 002	DK-S 11x 30	8 $^{+0.25}_0$	0.05	28 $^{+0.5}_{+0.1}$	4	2.5	11	30	35
					01 081 003	DK-S 11x 50		0.07					50	55
01 071 001	DK-A 15x 25			0.05	01 081 004	DK-S 15x 25		0.06					25	30
01 071 002	DK-A 15x 40	5	10 ± 0.2	0.08	01 081 005	DK-S 15x 40	11 $^{+0.25}_0$	0.10	36 $^{+0.5}_{+0.1}$	5	2.5	15	40	45
01 071 003	DK-A 15x 60			0.12	01 081 006	DK-S 15x 60		0.14					60	65
01 071 004	DK-A 18x 30			0.10	01 081 007	DK-S 18x 30		0.13					30	35
01 071 005	DK-A 18x 50	6	12 ± 0.3	0.16	01 081 008	DK-S 18x 50	12 $^{+0.25}_0$	0.20	45 $^{+0.6}_{+0.1}$	5	2.5	18	50	55
01 071 006	DK-A 18x 80			0.26	01 081 009	DK-S 18x 80		0.33					80	85
01 071 007	DK-A 27x 40			0.25	01 081 010	DK-S 27x 40		0.27					40	45
01 071 008	DK-A 27x 60	8	20 ± 0.4	0.37	01 081 011	DK-S 27x 60	22 $^{+0.25}_0$	0.40	62 $^{+0.7}_{+0.1}$	6	3	27	60	65
01 071 009	DK-A 27x100			0.62	01 081 012	DK-S 27x100		0.66					100	105
01 071 010	DK-A 38x 60			0.63	01 081 013	DK-S 38x 60		0.72					60	70
01 071 011	DK-A 38x 80	10	25 ± 0.4	0.83	01 081 014	DK-S 38x 80	30 $^{+0.25}_0$	0.94	80 $^{+0.8}_{+0.1}$	7	3.5	38	80	90
01 071 012	DK-A 38x120			1.22	01 081 015	DK-S 38x120		1.37					120	130
01 071 013	DK-A 45x 80			1.15	01 081 016	DK-S 45x 80		1.35					80	90
01 071 014	DK-A 45x100	12	35 ± 0.5	1.44	01 081 017	DK-S 45x100	35 $^{+0.4}_0$	1.65	95 $^{+1.0}_{+0.1}$	8	4	45	100	110
01 071 015	DK-A 45x150			2.12	01 081 018	DK-S 45x150		2.44					150	160
01 071 016	DK-A 50x120			2.35	01 081 019	DK-S 50x120		2.55					120	130
01 071 017	DK-A 50x200	M12x40	40 ± 0.5	3.75	01 081 020	DK-S 50x200	40 $^{+0.4}_0$	4.21	108 $^{+1.2}_{+0.1}$	8	4	50	200	210
01 071 018	DK-A 50x300			5.60	01 081 021	DK-S 50x300		6.45					300	310

List of torque and loads on page 1.5.

Further information to customized elements and installation examples as from page 1.14.



www.rosta.com