

Selection table for guided systems (crank driven)

				
One mass shaker "brute-force" system	One mass shaker "natural frequency" system	Two mass shaker "fast-runner" system with reaction force-compensation		
Single Rocker with adjustable length. Models with right-hand and left-hand threads. 7 sizes up to 5'000 N per rocker suspension.			AU Page 2.25	
Single Rocker with decided center distance. 6 sizes up to 2'500 N for flange fixation. 6 sizes up to 2'500 N for central fixation.			AS-P AS-C Page 2.26	
		Double Rocker with decided center distance. 5 sizes up to 2'500 N for flange fixation. 4 sizes up to 1'600 N for central fixation.	AD-P AD-C Page 2.27	
Single Rocker with adjustable length. Models with right-hand and left-hand threads. 7 sizes up to 5'000 N per rocker suspension.			AR Page 2.28	
Drive Head for crank drive transmission in shaker conveyors. Models with right-hand and left-hand threads. 9 sizes up to 27'000 N per drive head.			ST Page 2.29	
	Spring Accumulator with high dynamic spring value for feeder systems running close to resonance frequency. A spring accumulator consists of 2 DO-A elements. 5 sizes up to dynamic spring value of 320 N/mm.		DO-A Page 2.30	

Notes regarding some special shaker systems:

- For free oscillating systems on pages 2.16–2.19
- For guided systems on pages 2.31 – 2.33
- For gyratory sifters on page 2.34



Technology

1. One mass systems without spring accumulators: Calculation

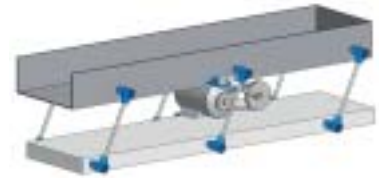

	Subject	Symbol	Example
Length, weight	Trough length	L	2.5 m
	Weight empty trough	m ₀	200 kg
	Weight of feeding material		50 kg
	Material coupling factor 50% *	m _m	25 kg
	Weight of oscillating mass *	m = m ₀ + m _m	225 kg
Drive parameter	Eccentric radius	R	12 mm
	Stroke	sw = 2 · R	24 mm
	Rpm on trough	n _s	340 min ⁻¹
	Gravity acceleration	g	9.81 m/s ²
	Oscillating machine factor	K	1.6
	Acceleration	a = K · g	1.6 g
	Total spring value of system	c _t	285 N/mm
Rocker arms	Distance between rockers max.	L _{max}	1.5 m
	Quantity of rockers	z	6
	Load per rocker	G	368 N
	Selection osc. elements (e. g.)		12x AU 27
	Selection ROSTA-elements: AU, AR, AS-P, AS-C		
	Center distance of elements	A	200 mm
Drive	Acceleration force	F	3423 N
	Selection drive head		1x ST 45
	Drive capacity approx.	P	1.0 kW
Spring value	Dynamic torque	M _d	2.6 Nm/°
	Dynamic spring value per rocker	c _d	7.4 N/mm
	Dynamic spring value of all rockers	Z · c _d	44.7 N/mm
	Resonant ability factor	i	0.16

Calculation formulas

Oscillating machine factor

$$K = \frac{\left(\frac{2\pi}{60} \cdot n_s\right)^2 \cdot R}{g \cdot 1000} = \frac{n_s^2 \cdot R}{894'500}$$

Total spring value (machine)

$$c_t = m \cdot \left(\frac{2\pi}{60} \cdot n_s\right)^2 \cdot 0.001$$

Quantity of rockers

$$z = \text{round up} \left(\frac{L}{L_{\max}} + 1 \right) \cdot 2$$

Load per rocker

$$G = \frac{m \cdot g}{z}$$

Acceleration force (ST selection)

$$F = m \cdot R \cdot \left(\frac{2\pi}{60} \cdot n_s\right)^2 \cdot 0.001 = c_t \cdot R$$

Drive capacity approx.

$$P = \frac{F \cdot R \cdot n_s}{9550 \cdot 1000 \cdot \sqrt{2}}$$

Dynamic spring value per rocker

$$c_d = \frac{M_d \cdot 360 \cdot 1000}{A^2 \cdot \pi}$$

Resonant ability factor

$$i = \frac{z \cdot c_d}{c_t}$$

* the following factors have to be considered by the definition of the material coupling:

- high coupling factor or sticking of wet and humid material
- possible stemming of the trough

2. One mass system with spring accumulators: Calculation

Calculation analog chapter 1 with following additions:

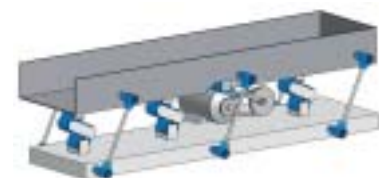

Spring accumulators	Quantity	z _s	2
	Dyn. spring value per item	c _s	100 N/mm
	Dyn. spring value of all items	z _s · c _s	200 N/mm
	Resonant ability factor	i _s	0.86
	Selection of accumulators		2x cons. of 2x DO-A 45 x 80

Resonant ability factor with accumulators

$$i_s = \frac{z \cdot c_d + z_s \cdot c_s}{c_t}$$

By a resonant ability factor i_s ≥ 0.8 the system is usually titled "natural frequency shaker".

Technology

3. One mass shaker conveyor systems: Installation instructions

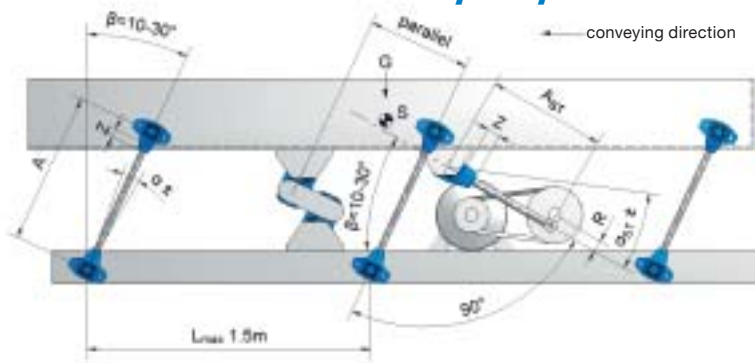

Distance between rockers L_{max} :

- Usually, the distance between the rocker arms on the trough along-side is up to 1.5 meters, depending on the stiffness of the trough.
- By trough widths >1.5 m we do recommend to provide the trough bottom side with a third, central row of rocker arms for stability reasons.

Mounting position drive head ST:

For one mass shaker systems it is recommendable to position the drive head slightly ahead of the center of gravity of the trough, towards the discharge end.

Rocker mounting angle β :

According to the relevant processing function of the shaker conveyor, the rocker arms are positioned at mounting angles between 10° to 30° in relation to the perpendicular line. (The ideal combination of fast conveying speed with high material throw is given by a rocker inclination angle of 30° .) The power input position of the drive-rod from the eccentric drive should stay at right angles to the rocker arms, this orthogonal positioning offers a harmonic course of the drive system.

Angle of oscillation α :

The machine parameters, angle of oscillation and revolutions should be determined in the admissible area of operations (see chapter 5).

Screw quality:

The screw quality should be grade 8.8 secured by the required tightening moment.

Depth of thread engagement Z :

The depth of engagement should be at least $1.5 \times$ the thread nominal width.

4. Average material speed on shakers v_m

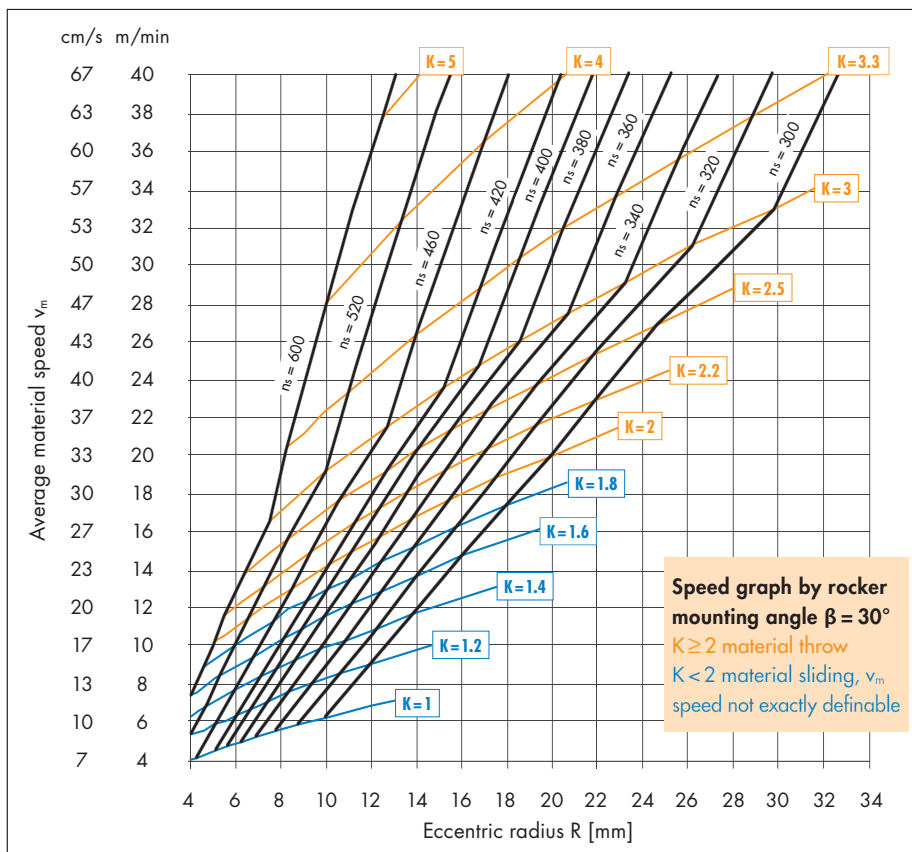

Main influence factors

- layer height of material
- property trough bottom (slip-resistance)
- mounting angle β of the rockers
- feeding capability of the material depending on size, form and humidity of the grains, e.g. very dry and fine grained material is submitted to slippage factors up to 30%.

Example: One mass system with eccentric drive

Out of the intersection point $R = 12 \text{ mm}$ and the revolutions $n_s = 340 \text{ min}^{-1}$ is resulting a theoretical material speed of $v_m = 12 \text{ m/min}$ or 20 cm/sec .

By acceleration factors $K > 2$ and rocker mounting angles of $\beta = 30^\circ$ (to the perpendicular line) the vertical acceleration is getting bigger than $1g$, therefore the material starts lifting from the trough bottom = material throw.

Technology

5. Maximum rocker load G , revolutions n_s and angle of oscillation α

Size (e.g. AU 15)	max. load capacity per rocker [N]				max. revolutions n_s [min ⁻¹]*	
	K < 2	K = 2	K = 3	K = 4	$\alpha \pm 5^\circ$	$\alpha \pm 6^\circ$
15	100	75	60	50	640	480
18	200	150	120	100	600	450
27	400	300	240	200	560	420
38	800	600	500	400	530	390
45	1'600	1'200	1'000	800	500	360
50	2'500	1'800	1'500	1'200	470	340
60	5'000	3'600	3'000	2'400	440	320

The angle of oscillation α of each oscillating component (rockers accumulators and drive head) has to be settled within the permissible range (n_s and α).

Calculation oscillation angle for rockers

Eccentric radius R [mm]
Center distance A [mm] $\alpha = \arctan\left(\frac{R}{A}\right)$
Oscillation angle $\alpha \pm [^\circ]$

Please contact ROSTA for the permissible load indications by higher accelerations and for rocker elements offering higher load capacities. Usually are the revolutions n_s between 300 to 600 min⁻¹ and the oscillation angles max. $\pm 6^\circ$.

* basics: "permissible frequencies" in the Technology part of the ROSTA catalogue.

6. Two mass shaker systems with direct reaction force-compensation

- Maximum acceleration forces of approx. 5 g, shaker lengths up to 20 meters
- Equipped with ROSTA double rockers **AD-P**, **AD-C** and/or made out of **AR** elements
- Ideal compensation when $m_1 = m_2$
- Element selection analogue chapter 1, but with load of the two masses:
Actuated mass (+ material coupling of feeding mass) m_1 [kg]
Driven mass (+ material coupling of feeding mass) m_2 [kg]
Total oscillating mass $m = m_1 + m_2$ [kg]

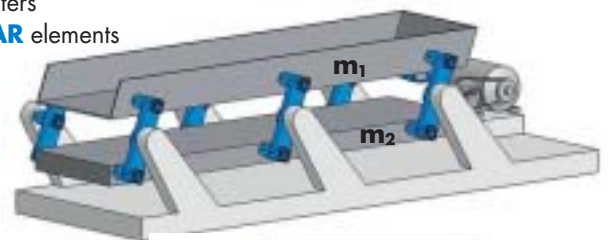

Dynamic spring value c_d per double rocker

$$c_d = \frac{3 \cdot M_{d1} \cdot 360 \cdot 1000}{2 \cdot A^2 \cdot \pi} \text{ [N/mm]}$$

- Calculation of c_i and F based on the total mass (m_1 and m_2)
- Power input from eccentric drive with **ST arbitrary** on m_1 or m_2 at **any point** alongside m_1 or m_2
- On demand, special double rocker arms with varying center distances A are available as "customized rockers"

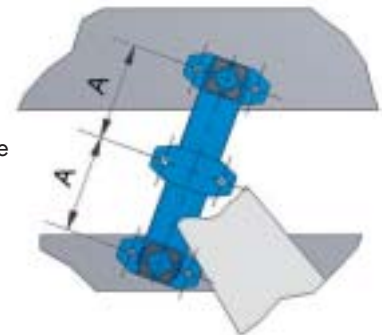

The 9 installation steps for a two mass system with double rocker arms:

1. All fixation holes for the rockers in trough, counter-mass and machine frame have to be drilled very accurately previous the final machine assembling.
2. Installation of the middle elements of the rocker arms on the central machine frame, all inclination angles duly adjusted (e.g. 30°), tightening of the screws with required fastening torque.
3. Lifting of the counter-mass with accurate horizontal alignment until the bores in the counter-mass frame stay congruent with the bore holes of the lower element. Jamming of the counter-mass with e.g. wooden chocks.
4. Tightening of the fixation screws on counter-mass with required fastening torque.
5. Inserting of the feeding trough into machine frame structure. Accurate horizontal alignment until the bores in the trough stay congruent with the bore holes of the upper element. Jamming of the trough with e.g. wooden chocks.
6. Tightening of the fixation screws on trough with required fastening torque.
7. Installation of the driving rod with drive head ST in "neutral" position i.e. eccentric drive should stay in between the two stroke ends. Length adjustment of the driving rod and tightening of the counternuts.
8. Removal of the jamming chocks under counter-mass and trough.
9. Test start of the shaker conveyor.

Double Rockers

**AD-P /
AD-PV**
for flange
fixation

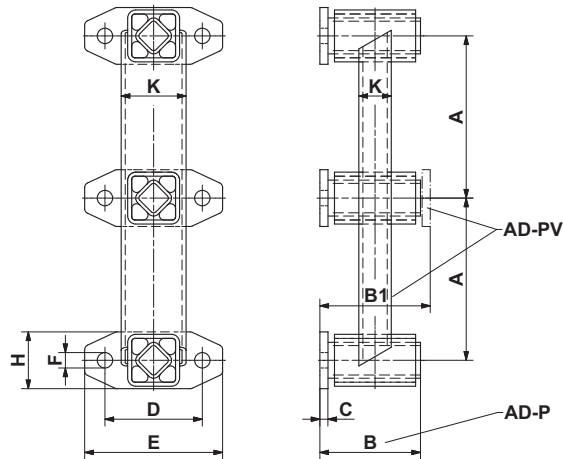

Type AD-PV with inverted flange

Art. No.	Type	G [N]		cd [N/mm]	A	B	B1	C	D	E	øF	H	K	Weight [kg]	Material structure				
		K=2	K=3																
07 111 001	AD-P 18	150	120	23	100	62	-	5	60	85	9.5	35	40 x 20	1.2	Steel welded constructions, ROSTA blue painted				
07 121 001	AD-PV 18					-	68												
07 111 002	AD-P 27	300	240	31	120	73	-	5	80	110	11.5	45	55 x 34	2.6		Steel welded constructions, ROSTA blue painted			
07 121 002	AD-PV 27					-	80												
07 111 003	AD-P 38	600	500	45	160	95	-	6	100	140	14	60	70 x 50	5.5			Steel welded constructions, ROSTA blue painted		
07 121 003	AD-PV 38					-	104												
07 111 004	AD-P 45	1'200	1'000	50	200	120	-	8	130	180	18	70	80 x 40	8.5				Steel welded constructions, ROSTA blue painted	
07 121 004	AD-PV 45					-	132												
07 111 005	AD-P 50	1'800	1'500	56	250	145	-	10	140	190	18	80	90 x 50	12.9					Steel welded constructions, ROSTA blue painted
07 121 005	AD-PV 50					-	160												

AD-C
for frictional
center connection

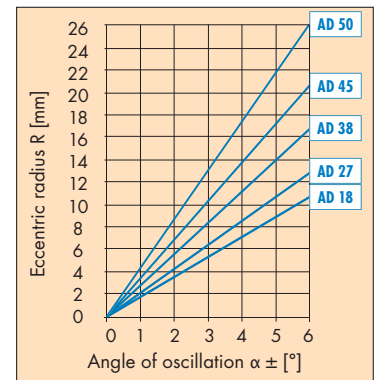
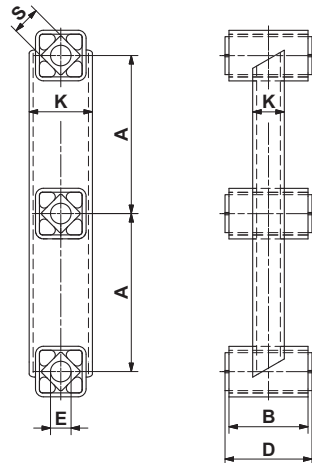

Art. No.	Type	G [N]		cd [N/mm]	A	B	D _{-0.3}	øE	K	□S	Weight [kg]	Material structure	
		K=2	K=3									Inner square	Housing
07 101 001	AD-C 18	150	120	23	100	50	55	13 _{-0.2} ⁰	40x20	18	0.8	Light metal profile	Steel welded construction, ROSTA blue painted
07 101 002	AD-C 27	300	240	31	120	60	65	16 _{+0.2} ^{+0.5}	55x34	27	1.8		
07 101 003	AD-C 38	600	500	45	160	80	90	20 _{+0.2} ^{+0.5}	70x50	38	4.1		
07 101 004	AD-C 45	1'200	1'000	50	200	100	110	24 _{+0.2} ^{+0.5}	80x40	45	6.1		

G = max. load in N per rocker, by different K consult chapter 5 on page 2.24.

cd = dynamic spring value by oscillation angles $\alpha \pm 5^\circ$ in speed range of $n_s = 300-600 \text{ min}^{-1}$